

## Para: Piloto participantes en Supersport300

### Notificación Técnica

28 de septiembre de 2018

De cara a la última prueba del Campeonato de España Cetelem de Velocidad a celebrar en el Circuito de Jerez Ángel Nieto, los próximos días 20 y 21 de octubre de 2018, se aplicarán las siguientes actualizaciones de reglamento:

#### **2.6.9 Electricidad y Electrónica** **2.6.9.1 Encendido / Unidad de Control del Motor (ECU)**

El ajuste inicial del limitador de RPM es:

Motocicleta:	Máx RPM
Honda CBR 500 R	10.200 rpm
Kawasaki Ninja 300 (EX300ADF)	13.000 rpm
Kawasaki Ninja 400 (EX400G/H/J)	10.000 rpm
Yamaha YZF-R3	13.000 rpm
Yamaha YZF-R3/A (kit)	13.000 rpm
KTM RC390	10.700 rpm
KTM RC390 R	10.700 rpm

#### **Las siguientes modificaciones adicionales estarán autorizadas (dossier Yamaha adjunto):**

Yamaha R3 and Yamaha R3A:

Kit suministrado por Yamaha, que incluye: árbol de levas de escape, juntas, trompetas de admisión (mirar dossier Yamaha)



YZF R3 WSSP 300

ENGINE UPGRADE KIT MANUAL

FIM / DORNA

**SUPERSPORT300** ◀  
FIM WORLD CHAMPIONSHIP

Yamaha approved parts Portimão 2018

04 September 2018

# Contents

1	General Information.....	2
	1.1.1 How to use this manual.....	3
	1.1.2 Disclaimer of warranty.....	3
	1.1.3 Technical disclaimer.....	3
	1.1.4 Engine Specification.....	4
2	Engine Upgrade kit part list.....	5
	2.1 Camshafts.....	5
	2.1.1 Item List.....	5
	2.2 Air Funnels.....	6
	2.2.1 Item List.....	6
3	Hint.....	7
4	Race Service.....	7

# 1 General information

## 1.1 How to use this manual

This manual is intended for people with knowledge and experience in the assembly of motorcycle engines. For information on the assembly and maintenance of parts not mentioned in this manual, refer to the YZF-R3 service manual (cod: BR5-F8197-H0) and to the YZF-R3 parts catalogue (cod:1TBR5-300E1) published by YAMAHA MOTOR CO.

The design of the YZF-R3 engine upgrade kit is based on the YZF-R3, according to the FIM WSBK competition technical regulations, but this does not mean that the kit complies with other competition technical rules. When used in different competitions other than WSSP 300, teams use the kit parts at their own responsibility after checking the specific competition regulations issued.

## 1.2 Disclaimer of warranty

PLEASE NOTE THAT THESE PARTS ARE NOT COVERED BY ANY WARRANTY EXPRESSED OR IMPLIED.

THE MANUFACTURER ASSUMES NO RESPONSIBILITY FOR ANY PROBLEMS CAUSED BY THESE PARTS.

## 1.3 Technical disclaimer

These parts of the kit are intended exclusively for competition use. It is strongly requested not to use the mentioned kit on public roads.

Technical data, methods of use of these kit's parts and contents of this manual are subject to change without notice for improvement of performance.

## 1.4 Engine Specifications

Spec		WSSP 300	YZF R3 / BR0	YZF R3 A / BR5
Displacement		321cm <sup>3</sup>	321cm <sup>3</sup>	321cm <sup>3</sup>
Bore/Stroke		68.0 x 44.1 mm	68.0 × 44.1 mm	68.0 × 44.1 mm
Maximum engine speed (limiter controlled speed)		13000 rpm	12200 rpm	12200 rpm
Compression ratio (recommended value)		12.1 – 12.3 * Depending on head surface grinding	11.2	11.2
Valve timing (event angle) at TDC	INT	112° *	–	–
	EXT	113°	–	–
Clearance between valve and piston (minimum)	INT	1 mm *	–	–
	EXT	1.6 mm *	–	–
Valve (tappet) clearance	INT	0.13 – 0.17 mm *	0.11 – 0.18 mm	0.11 – 0.18 mm
	EXT	0.18 – 0.23 mm	0.21 – 0.30 mm	0.25 – 0.32 mm

**NOTICE**

\*The data are indicative and detected with the new engine

## 2 Engine Upgrade kit part list

Part Number	Part Name	Quantity	Note
1WD-E2180-01	Shaft, Cam 2 Exhaust	1	
007-90105-07800	Bolt	2	
007-E4469-00	Air Funnel	2	

### 2.1 Camshafts

#### 2.1.1 Item List

Part Number	Part Name	Quantity	Note
BR5-E2170-00	SHAFT, CAM 1 INTAKE	1	No Change from actual one
1WD-E2180-01	SHAFT, CAM 2 EXHAUST	1	Update Kit Part
007-90105-07800	Bolt	2	Update Kit Part

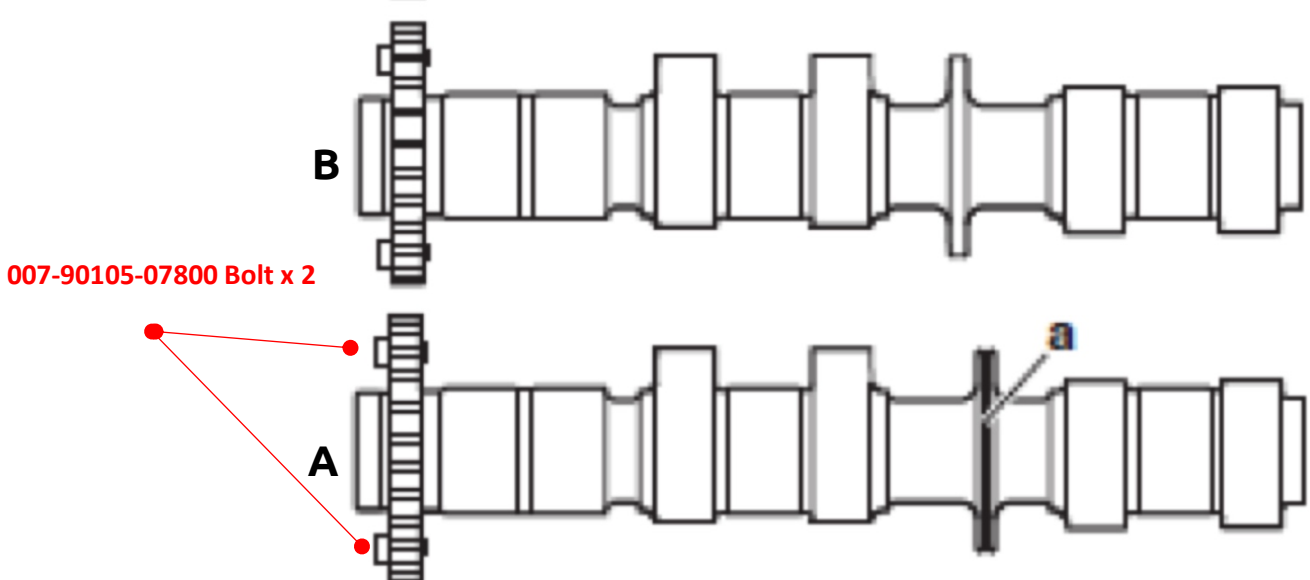

**A. Shaft, Cam 2 Exhaust 1WD-E2180-01**

**B. Shaft, Cam 1 Intake BR5-E2170-00 or 2MS-E2170-01**

#### **Assembly Procedure different from OEM:**

Fit the piece 1WD-E2180-01 apply the gear in your possession (make sure it is in perfect condition) use **007-90105-07800, Bolt** for correct timing, make sure that the gear is turned anticlockwise and at the end of stroke, then lock **007-90105-07800, Bolt** with a tightening calibrated using a dynamometric wrench (20Nm – 2.0Kgf – 15lbft).

For all the rest please reference to BR5-F8197-H0 service manual.

## 2.2 Air Funnels

### 2.2.1 Item List

Part Number	Part Name	Quantity	Note
007-E4469-00	Air Funnel	2	Update Kit Part

### **Assembly Procedure & Design:**

Attention, before to apply the new Air funnels code 007-E4469-00 cut 2MS-E4469-00 & 2MS-E446C-00 at the base of the throttle body, after that, insert the new aluminum part with interference till the stopper.

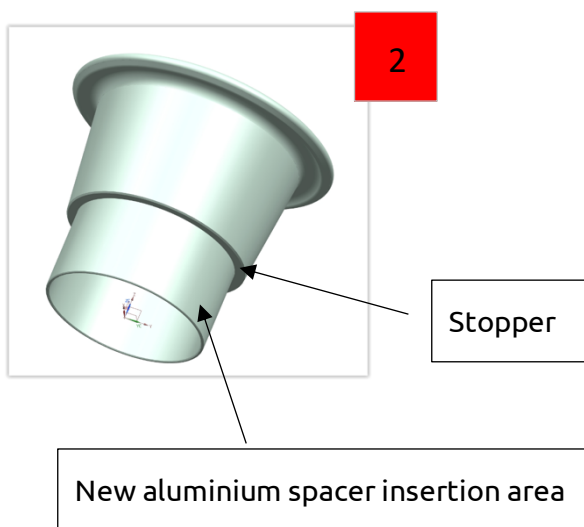
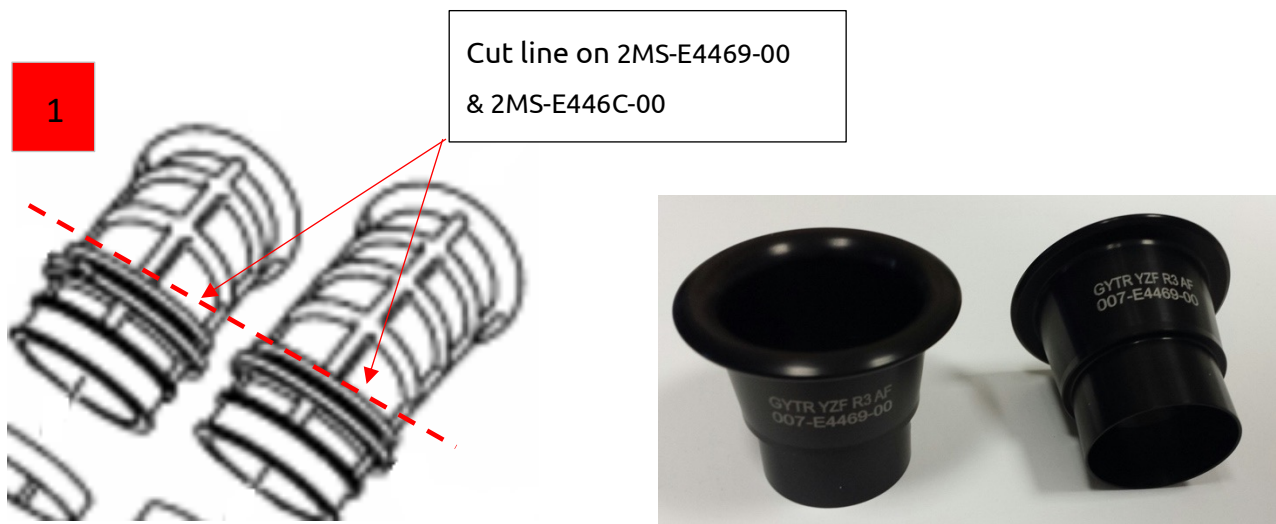

### 3 Hint

During engine assembly it is recommended to keep everything clear and tidy.

To avoid making mistakes it is advisable to keep the replaced parts separate from the parts of the kit. Keep also note of mounted components by recording everything including the mileage of each part.

When parts are reused, clean and check for damage, deterioration or excessive wear.

### 4 Race Service

During the Race weekend in Portimano there will be a race service technician to support the team to set up the parts in case they needed.

Please contact Alberto Barozzi *bLU cRU* racing manager : + 39 335 420589

## Thanks for your attention